

Volgdisplay Type RD52HL



Volgdisplay met hoge intensiteit

Seriële verbinding met weegapparatuur

Zichtbaarheid van cijfers tot een afstand van ca. 30 m

Roestvast stalen behuizing (IP65) – compleet met beschermkap en bevestigingsbeugel

Goedkeuring volgens OIML – getest en goedgekeurd volgens EN45501 standaard



Specificaties

Voeding:

100/240 VAC +/- 20%
50/60 Hz 50 mA

Voedingskabel:

Lengte 4 m

Omgevingstemperatuur:

Van -10° C tot +50° C

Cijferhoogte:

60 mm

Interfaces:

EIA RS232 (tot 15 m)

EIA RS422 (voor grotere afstanden)

Behuizing:

Roestvast stalen behuizing (IP65), compleet met beschermkap en bevestigingsbeugel

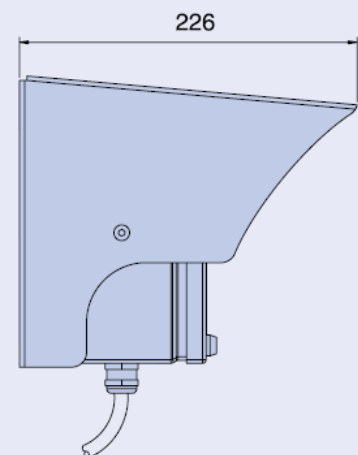
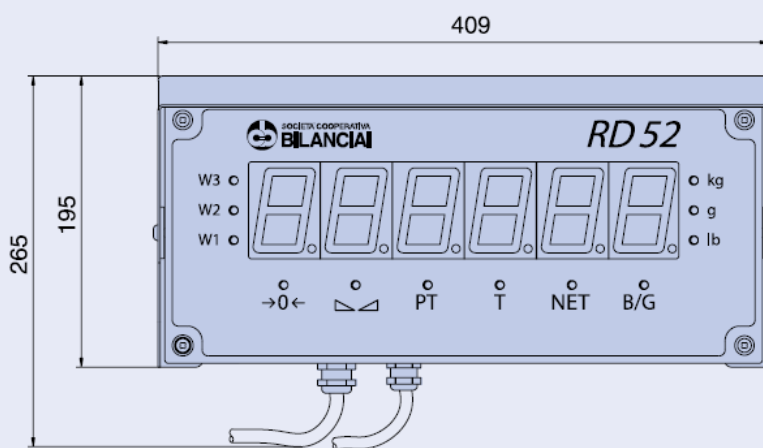

RD52HL – ed. 1.6/1120



Bel ons:
0162 430 450



Technologieweg 6
4906 AC Oosterhout



E-mail ons:
office@pfisterweegtechnik.nl